

SECTION A-A

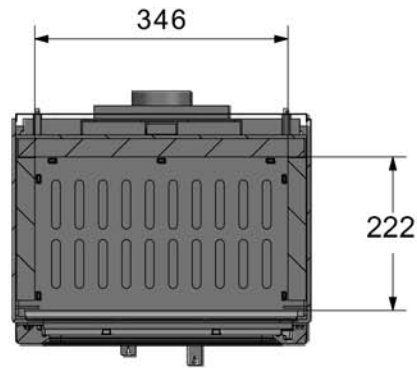

SECTION B-B

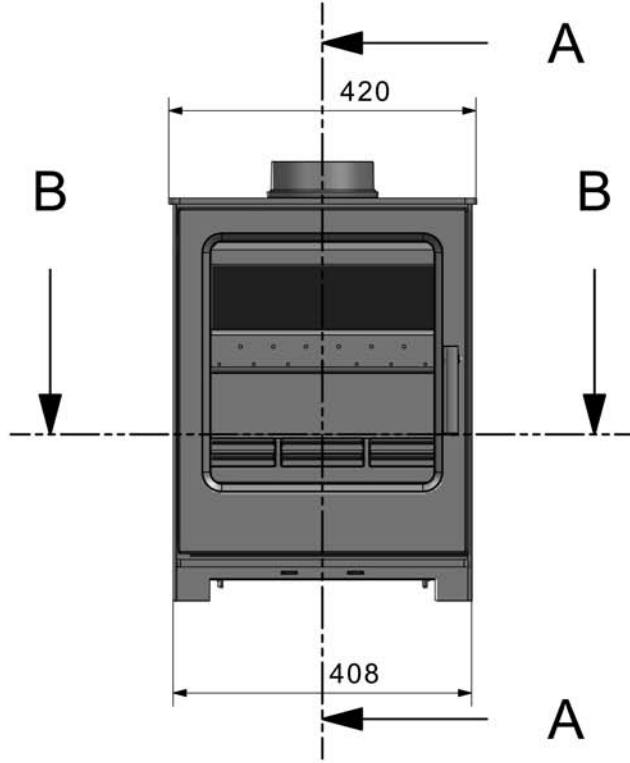
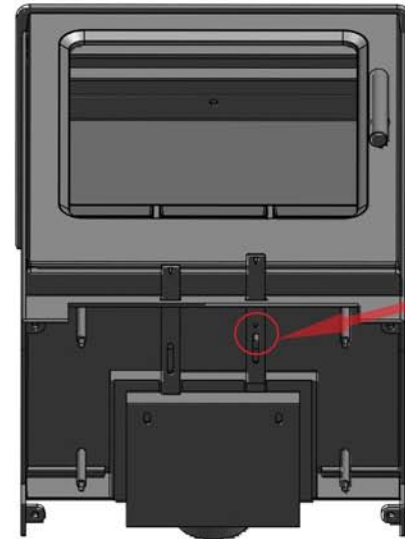
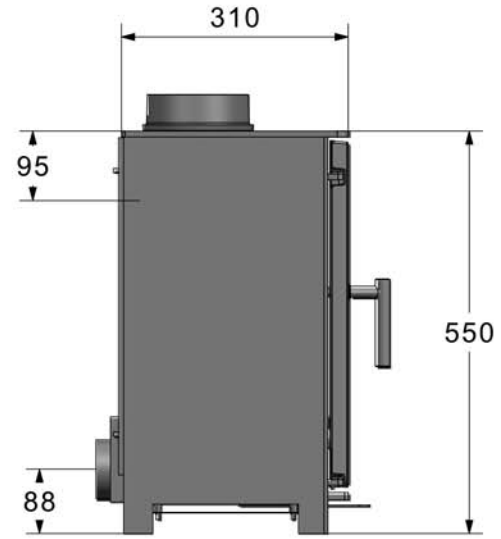

We will use a screw here for preventing closure of secondary air control beyond 8mm open

