

SLOT GLASS

TECHNOLOGY

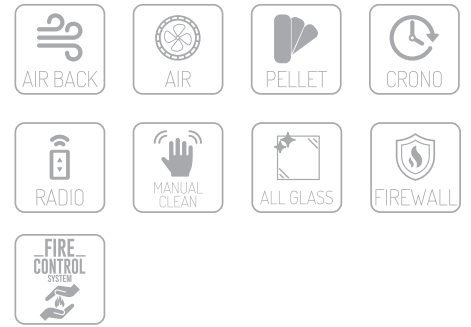

Ventilazione Frontale (1 Motore) – Uscita Fumi Superiore

Front Ventilation (1 Motor) – Top Exhaust Fume Outlet – Ventilation Frontal (1 Moteur) – Salida De Humos Superior – Ventilation Avant (1 Moteur) – Sortie De Fumée Supérieur – Front Gebläse (1 Motor) – Rauchausgang Oben

OPTIONAL



Potenza Globale
Global Power
Puissance globale
Potencia global
Verbrennungsleistung

Rendimento totale
Total efficiency
Puissance globale
Potencia global
Pellet Wirkungsgrad

Peso
Weight
Poids
Gewicht

Consumo min-MAX
Min-Max consumption
Consumation min-MAX
Consumo min-maxi
Min-Maxi verbrauch

Temperatura gas di scarico
Exhaust gas temperature
Température des gaz d'échappement
Temperatura de los gases de escape
Abgas Temperatur

Tiraggio richiesto in funzionamento
Draw required in operation
Dessiner nécessaire en fonctionnement
Dibujar requerido en la operación
Erforderlicher Betriebszug

Uscita fumi
Chimney Output
Sortie conduit de cheminée
Salida conducto de humos
Rauchauslass

Ingresso aria
Air inlet
Entrée d'air
Entrada aire
Lufteinlass

Serbatoio pellet
Pellet Tank
Reservoir
Deposito
Tank Fassungsvermögen

Absorbimento elettrico
Electrical consumption
Absorption électrique
Consumo de electricidad
Elektrischer Verbrauch

	Potenza Globale Global Power Puissance globale Potencia global Verbrennungsleistung	Rendimento totale Total efficiency Puissance globale Potencia global Pellet Wirkungsgrad	Peso Weight Poids Gewicht	Consumo min-MAX Min-Max consumption Consumation min-MAX Consumo min-maxi Min-Maxi verbrauch	Temperatura gas di scarico Exhaust gas temperature Température des gaz d'échappement Temperatura de los gases de escape Abgas Temperatur	Tiraggio richiesto in funzionamento Draw required in operation Dessiner nécessaire en fonctionnement Dibujar requerido en la operación Erforderlicher Betriebszug	Uscita fumi Chimney Output Sortie conduit de cheminée Salida conducto de humos Rauchauslass	Ingresso aria Air inlet Entrée d'air Entrada aire Lufteinlass	Serbatoio pellet Pellet Tank Reservoir Deposito Tank Fassungsvermögen	Absorbimento elettrico Electrical consumption Absorption électrique Consumo de electricidad Elektrischer Verbrauch
A10	KW 10,4-3,1	% 90,8	Kg 176	Kg/H 0,7-2,5	°C 166	Pa 10	mm 80	mm 60	Kg 12	W 100
A8	KW 8,0-3,1	% 90,8	Kg 176	Kg/H 0,7-2,0	°C 155	Pa 10	mm 80	mm 60	Kg 12	W 100

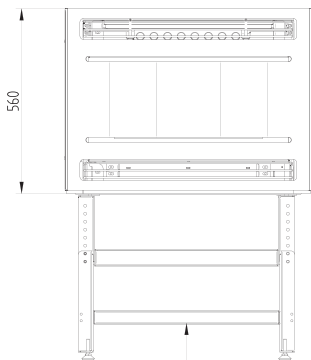

OPTIONAL

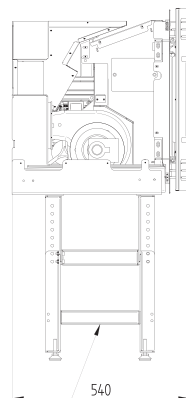

OPTIONAL

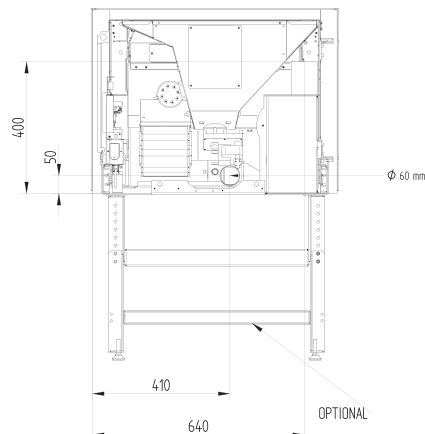

OPTIONAL

USCITA FUMI
Ø 60mm

